

# Real Time Signal Compression in Radar Using FPGA

Enrique Escamilla-Hernández<sup>1</sup>

Victor Kravchenko<sup>2</sup>

Volodymyr Ponomaryov<sup>3</sup>

Daniel Robles-Camarillo<sup>3</sup>

Luis E. Ramos V.<sup>1</sup>

<sup>1</sup>UAEH, CITIS, Carr. Pachuca-Tulancingo km 4.5, CP 42184, Pachuca, Hidalgo. MÉXICO.

<sup>2</sup>Institute of Radio Engineering and Electronics, Moscow. RUSIA.

<sup>3</sup>IPN ESIME Culhuacan, Av. Santa Ana 1000, Col. San Fco. Culhuacan, 04430, Mexico-city. Mexico MÉXICO.

Teléfono: 5729 6000, exts. 54755 y 54756

correo electrónico: zecmol@uaeh.edu.mx  
vponomar@ipn.mx

Recibido el 3 de septiembre de 2007; aceptado el 19 de marzo de 2008.

## 1. Abstract

This paper discusses the performance of different windows functions when they are applied in a radar system during pulse compression. The paper proposes too the implementation of a radar processing procedures in real time mode on FPGA architecture. The radar signal compression processing is done with matched filter applying classical and novel window functions, where we focus to study better solution for the side-lobes decreasing. Experimental results show that best results for pulse compression performance have been obtained using atomic functions, improving the performance of the radar system in the presence of noise, and getting small degradation in range resolution. Implementation of the signal processing in the radar system in real time mode is discussed and justified the effectiveness of the proposed hardware.

**Key words:** pulse compression, synthetic aperture radar (SAR), atomic functions, windowing.

## 2. Resumen

En este trabajo se discute el funcionamiento de diferentes funciones de ventanas aplicadas a la compresión de pulsos de radar. Se propone además la realización de esquemas de procesamiento de radar usando arquitecturas de FPGA. Aquí la compresión de señales de radar se lleva a cabo usando filtros acoplados con funciones de ventanas clásicas y otras novedosas, llamadas funciones atómicas, en la cual se pone especial énfasis en la supresión de los lóbulos laterales. Resultados experimentales muestran que se obtiene un mejor funcionamiento al utilizar funciones atómicas, en comparación con las clásicas, especialmente en presencia de ruido.

**Palabras clave:** compresión de pulsos, radar de apertura (SAR), funciones atómicas.

## 3. Introduction

There are a number of different methods used in digital signal processing to improve the performance of the radar systems. Most of them are based on the procedures to distinguish different objects by the recognition of the properties of the target (humidity cartography, analysis, etc.) [4, 5]. Different criteria are applied in the radar signal processing, such as: maximization of signal to noise relation (SNR), Neumann-Pearson criterion in the target detection problem, minimum of mean square error, etc. [1, 2]. The pulse duration determines the resolution of the system when it is measured in the signal propagation direction, so shorter pulses time let having better resolution. Restrictions on wave band channels and systems frequency response impose limits to thinner pulses; however these limitations can be improved using windowing processing to reduce the side-lobes distortion.

The selection of the radar signal is based on other important factors; among them we find power considerations, maximum resolution and range distance. The search of such a waveform pulse that satisfies those criteria have been studied deeply [1-4]. Usually, the radar pulse with linear FM chirp has emerged as a convenient solution in comparison with others wave forms [2].

In order to decrease the probability of false alarm, some windows functions are used [6, 7]. These functions are usually applied in time domain with the purpose to decrease the side lobes levels by processing the signal pulse with techniques that let us decrease the possibility to confuse such a side lobe with a target that has less power or size.

The new FPGAs architecture presents advances in their capacity and performance; they have certainly emerged as leader implementation of digital systems. They have now captured the imagination of diverse communities, such as computer architects, researches looking from fingerprint recognition, image processing or bioinformatics, among others [8].

FPGAs also offer much of the flexibility of programmable DSP processors, having additional performance that let applications developed in them be closer to specific solutions and going faster to special purpose integrated circuits (ASICs) or "commercial off-the-shelf" (COTS) platforms [8]. In this paper we discuss an FPGA implementation of radar signal during pulse compression using windowing procedures.

The paper is organized as follows: Section 2 discusses pulse compression radar considerations. Section 3 presents the hardware implementation of proposed compression model and windowing operations. Cordic algorithm for forming of square root value used in the compression algorithm is discussed in Section 4. Characteristics of different windows are presented in Section 5. Section 6 contains the experimental results of the proposed realization and atomic function selected for best windowing. Finally, we draw our conclusions.

#### 4. Pulse compression radar

Pulse compression method is based on the usage of long especially modulated pulses that are transmitted, but shorter output pulse signals with improved SNR can be obtained by pulse compression. This pulse compression is implemented with matched filter at reception stage. Such a technique is being used extensively in radars because it lets to get higher detection ranges due to increasing transmitted energy, realization of high range resolution, and effective interference and jamming suppression. Different type of modulations in the pulse can be used, such as linear/nonlinear frequency modulation signals (chirp modulation) or discrete phase code modulation. Radar systems such as Doppler radar or SAR frequently use linear chirp modulation.

The linear signal FM chirp can be represented as:

$$S(t) = \begin{cases} S_0(t)\cos(\omega_0 t + \mu t^2/2), & |t| < \tau_p/2 \\ 0 & \text{other} \end{cases} \quad (1)$$

In here,

$S_0(t)$  is the signal amplitude,  
 $\omega_0$  central frequency,  
 $\mu$  is a compression coefficient, and  
 $\tau_p$  is impulse duration.

The usage of the long duration pulses in radar system with pulse compression processing gives several advantages:

- Transmission of long pulses gives an efficient usage of the average power capability of the radar;
- Generation of high peak power signals is also avoided;
- Average radar power may be increased without increasing the pulse repetition frequency (PRF);
- Decreasing of the radar's unambiguous range can be achieved.

Better resolving capability in Doppler frequency shift is also obtained as a result of using long pulses. Additionally, the radar is less vulnerable to interfering signals that differ from the coded transmitted signal.

Usually a matched filter is applied on the pulse compression stage, and multiple delays and correlators are used to cover the total range of interval of interest. The output of the matched filter is the compressed pulse accompanied by responses on the targets at other ranges, called time or range side lobes. The matched filter at the receiver makes the restoration of the initial waveform. It is well known that the impulse response  $h(t)$  of such a filter is the complex conjugate of the time-reversed chirp:

$$h(t) = kS^*(-t + \tau_p) \quad (2)$$

where  $S(t)$  is the transmitted reference signal, so, the output of the matched filter can be written as  $g(t)$ :

$$g(t) = 1/T \int_{-T/2}^{T/2} r(t)S^*(t - \tau)dt \quad (3)$$

where  $r(t)$  is the received signal; function  $g(n)$  presents discrete time case and is represented by equation:

$$g(n) = 1/N \sum_{k=0}^{N-1} r(k)S^*(n - k) \quad (4)$$

Figure 1 shows the model for the pulse compression implementation. We used in our model for pulse compression four FIR filters with real and imaginary parts at the input. The signal reference is also presented by real and imaginary parts. The real part of pulse compression is calculated by adding the outputs of FIR 1 and FIR 2, and the imaginary part by adding

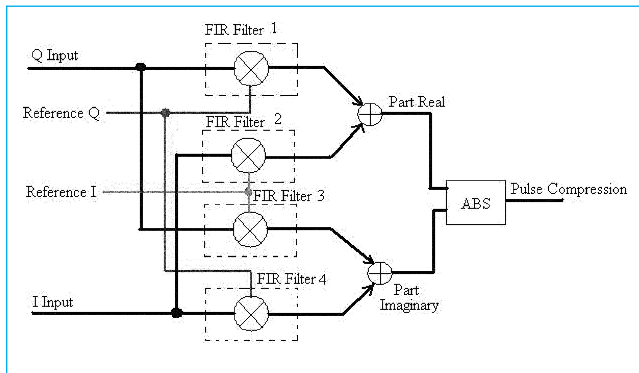

Fig. 1. Model for pulse compression.

FIR 3 and FIR 4 outputs. Finally, the absolute value (ABS) of the complex signal is calculated applying the ABS CORDIC algorithm, which lets get the pulse compression.

We show in Fig. 2 pulse compression stages in matched filters, frequency weighting of the output signals is usually employed to reduce the side-lobes. Such side-lobes can result in a mismatched conditions and lead to a degradation of the output SNR of the matched filter. In the presence of Doppler frequency shifts, a bank of matched filters is required, where each filter is matched to a different frequency then covering the band of expected Doppler frequency shifts.

### 5. Hardware implementation

High gate count and switching speed of modern FPGA is enabling high data-rate DSP processing to be performed without resorting to ASIC technology. Static RAM based FPGA also enable solutions to be reprogrammable. Then the soft solutions offer flexibility, which is an important attribute of a modem radar system. Consequently, FPGA implementations are attractive in applications where their relatively high unit cost and power consumption are not critical [8, 15].

Modern phased array radar relies heavily on DSP to achieve high levels of system performance and flexibility, but FPGAs represent an opportunity to achieve the required processing performance, and also reprogrammability that is an important aim of the radar systems, thereby enabling simplified system development and upgrade.

It has been tested in this work the performance of the FPGAs to generate the radar signal and realize the pulse radar compression.

We used the radar data with the next parameters: signal is linear FM (Chirp), frequency deviation ( $\Delta f$ ) is 9.375MHz, the

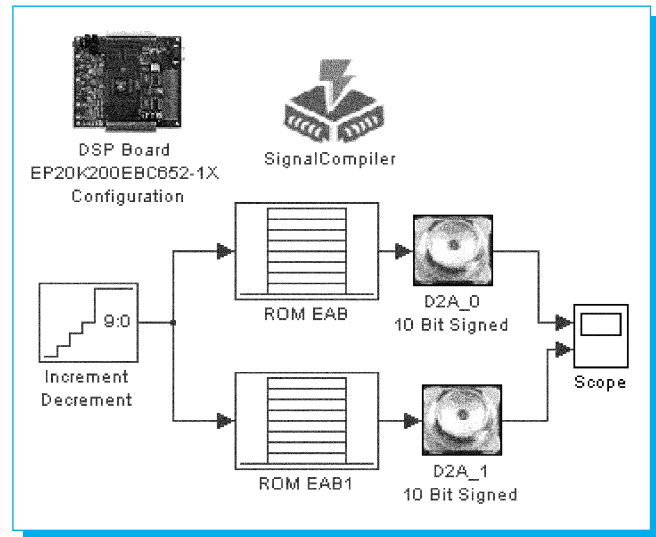

Fig. 2. Radar pulse model.

pulse width ( $\tau_p$ ) is  $3.2\mu s$ , sampling frequency is 40MHz [10]. We employed the Kit Altera FPGA to realize the radar pulse operation.

The model applied to generate the pulse is shown in Fig. 3. Two ROM blocks are used to form the values for real and imaginary parts of a pulse. A cycle counter is applied to design repetitive radar pulse and two DAC are used to convert digital to analog form.

The matched filter implementation on FPGA let us eliminating special chips previously needed. We have tested the performance of such a model in the FPGA Xilinx model VIRTEX II XC2V3000. The hardware Xtreme DSP II and programming software: Matlab 6.5, Simulink, System Generator and FUSE made possible to implement on the FPGA the pulse compression processing in real time mode. Analyzing different approaches we finally found the final FPGA system structure proposed in Fig. 3.

The main advantages of proposed structure (the software and FPGA hardware) is the facility whereupon we can easily change the parameters of each a block of the system. It is required in some applications to increase the precision of the system, and then increasing number of bits can be realized in each used block, that let us flexibility to adjust the parameters of the system, and therefore better solutions.

The number of taps in each FIR filter shown in Fig.1 was 65, realizing the matched filter as it is shown in Fig.3.

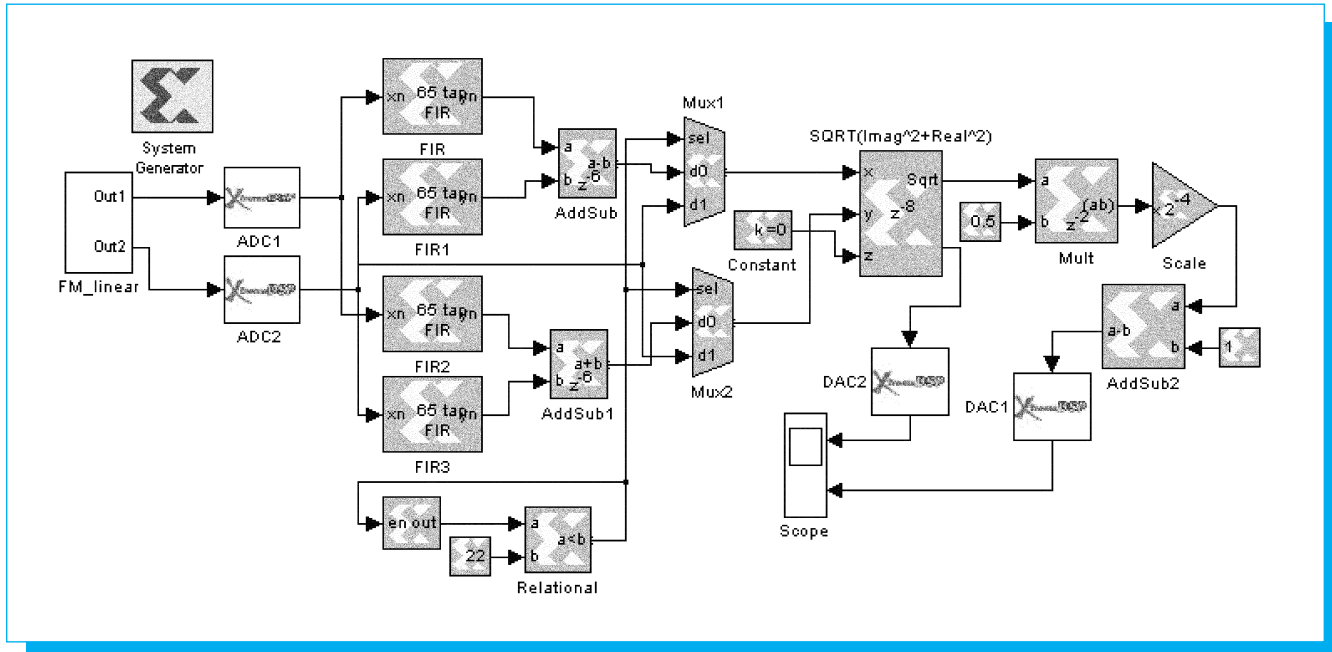

Fig. 3. Hardware FPGA model.

The SQRT block presented in Fig. 4 calculates the magnitude the output of matched filter. CORDIC algorithm is presented in the next section and it is applied to calculate such a magnitude.

### 6. Cordic algorithms

The algorithm CORDIC (Coordinate Rotation Digital Computer) is an iterative technique widely known and studied to evaluate many operations, such as: basic arithmetical and mathematical functions [16]. The CORDIC method can be employed in two different modes, known as the rotation and vectoring mode. The coordinate components of a vector and an angle of rotation are given in the rotation mode, so the coordinate components of the original vector are computed after rotation through a given angle. In the case of vectoring mode, the coordinate components of a vector are given and the magnitude and angular argument of the original vector are computed [16, 17].

In here we analyze vectoring mode to approach the square root value. The CORDIC rotator rotates the vector of the input by any angle necessary to align the resulting vector with x axis. The result of the operation vectoring is a rotation angle and the scaled magnitude of the original vector (component x of the result). The function vectoring works trying to reduce to the minimum y component value of the residual vector in

each rotation. The sign of the residual vector y is used to know the direction of the next rotation. If the value of the angle is initialized with zero, it has to contain the angle crossed at the end of the iterations. According to the model for the pulse compression implementation it is necessary to calculate the square root value. The equations to calculate magnitude value of the complex signal during the pulse compression are defined by iterative equations presented below:

$$x_{n+1} = x_n - d_n y_n 2^{-n} \tag{12}$$

$$y_{n+1} = y_n - d_n x_n 2^{-n} \tag{12}$$

Here:

$$d_n = \begin{cases} -1 & \text{if } y_n \geq 0 \\ +1 & \text{if } y_n < 0 \end{cases}$$

and finally

$$x_n = A_n \sqrt{x_0^2 + y_0^2}$$

$$A_n = \prod_n \sqrt{1 + 2^{-2i}}; \quad y_n = 0$$

### 5. Performance of diferent windows

The performance of different windows has been widely studied; researchers are especially interested in improving its

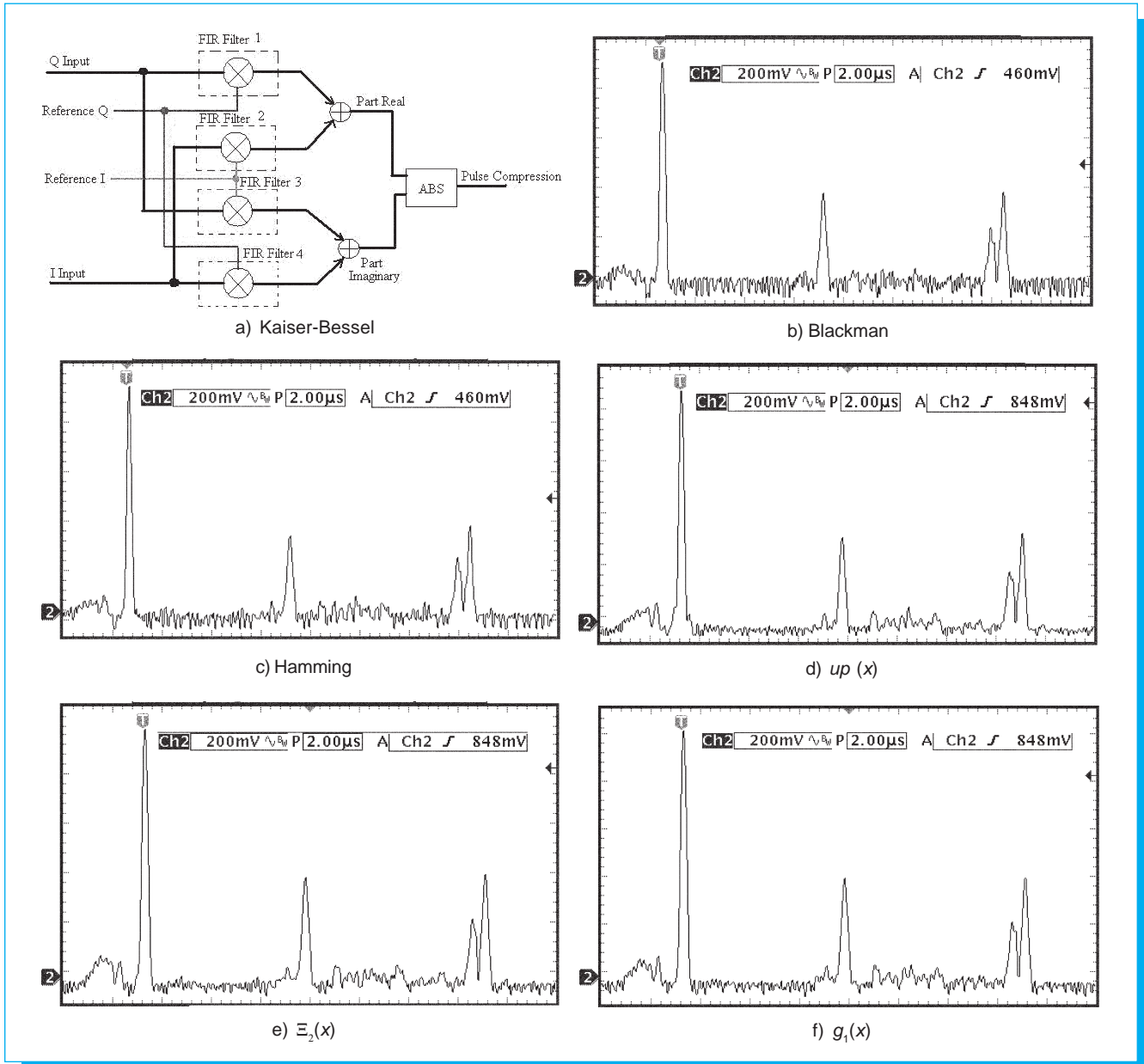

**Fig. 4.** Real time hardware results in detection of the multiples targets.

sidelobe behavior. Parameters values in pulse radar processing have been obtained from the application of different classical and novel windows, the most significant parameter values are shown in table 1.

These parameters are known as: *window gain*, *side lobe level*, *main lobe width*, and *the coefficient of noise performance*, all those parameters are defined below [6, 7, 9]:

$$\text{window gain, } K_{\text{gain}} = 0.5 \int W(t)dt \tag{14}$$

where  $W(t)$  represents the model of the window used; *side lobe level* is determined as equation (15)

$$10 \log \left( \max \left| \frac{S_{\text{com}}(t_k)}{S_{\text{com}}(t=0)} \right|^2 \right) \tag{15}$$

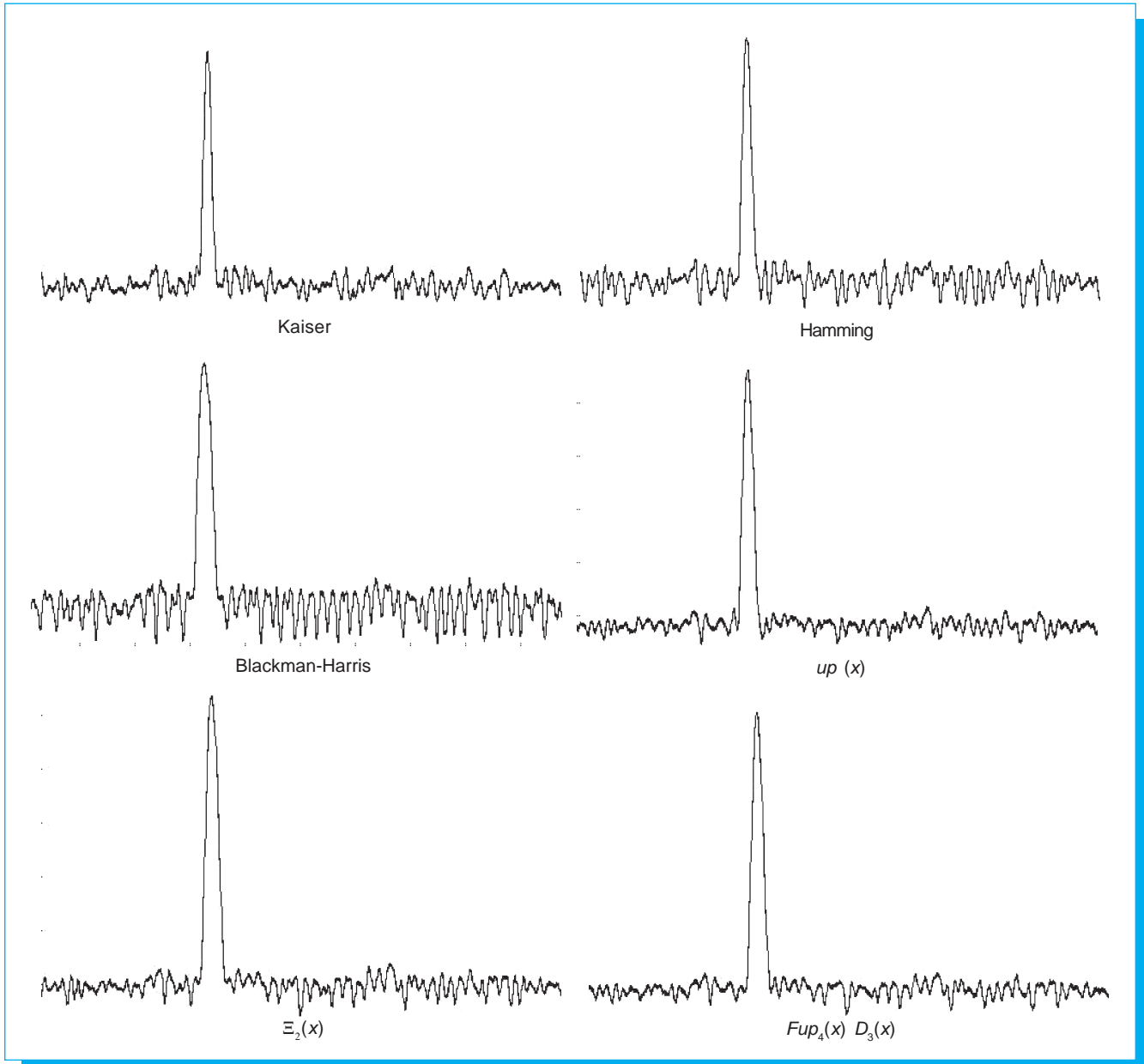

Fig. 5. Main lobe in real time pulse compression for different windows in presence of noise (SNR = 20dB).

$$10 \log \left( \frac{|S_{com}(t=0)|}{|S_{com}(t)|^2} \right) = 6 \text{ dB} \quad (15)$$

where  $S_{com}(t)$  is compressed signal after window processing; and, finally coefficient of noise performance is the relation indicated in equation (17)

$$\frac{SNR_{window}}{SNR_{rectangular}} \quad (17)$$

We can observe from table 1 that after applying different windows the best classical window performance for radar pulse compression belongs to the Hamming window, these is due to it has a 0,54 gain value, -32dB level of the side lobes, and a main lobe width of 239.2 ηs. One can see that the main lobe width is near double than the 129 ηs of rectangular window main lobe width.

However, comparing each one of all applied windows with Hamming window one we can conclude the following.

**Table 1.** Numerical hardware processing results.

Window	Sidelobe level (dB)	With main lobe at $-6\text{dB}(\eta_s)$
Rectangular	-14.1	124
Blackman 4 term	-31.8	274
Blackman	-32.0	230
Chebyshev	-31.7	272
Hamming	-33.3	196
Hanning	-31.8	214
Kaiser-Bessel	-31.1	172
$g_k(x)$ , $k = 0.5$	-31.0	292
$g_k(x)$ , $k = 1$	-32.2	285
$fup_1(x)$	-29.2	259
$fup_{15}(x)$	-30.5	570
$fup_{16}(x)$	-29.8	356
$\Xi_2(x)$	-31.2	294
$\Xi_3(x)$	-29.2	383
$Up(x)$	-29.8	258

The function  $fup_4$  offers smaller attenuation in the amplitude of the main lobe, as well as a lower main lobe width in comparison with the Hamming window. Because the attenuation of the side lobes is one of the most important parameters, so the function  $up(x)$  can be employed with advantages since it shows a better performances. Additionally, other windows already designed [9] have been implemented and applied in radar processing, a comparison performance of them let us take the next conclusions:

Observing results in table 1 we can conclude that the best result can be obtained using novel window such as the  $Fup_4(x)D_3(x)$ . Those best results are in the side lobes attenuation as well as in the smaller attenuation criteria.

## 8. Results of hardware implementation

Experimental results measured from the implemented radar processing model presented in Fig. 6, let us conclude that the Kaiser-Bessel function gets the highest selectivity among classical windows due to its better resolution performance of the near targets. Also it is easy to see that  $up(x)$  and  $\Xi_2(x)$ , (novel windows) are getting the best results in terms of the side-lobes levels. All studied windows have shown similar results in the resolution ability of the multiple targets.

Figure 7 shows the pulse compression signal using some classical and atomic function windows in presence of noise with SNR=20 dB. The windows: Hamming, Kaiser-Bessel,  $up(x)$ ,  $\Xi_2(x)$ ,  $Fup_4(x)D_3(x)$  were employed in here. The best results are realized by AF  $up(x)$ , because this function

presents the small side-lobes and good resolution. Another window that has good characteristics in the noise presence is  $Fup_4(x)D_3(x)$ , but the gain is smaller than for  $up(x)$  function.

The maximum amplitudes of side lobes and width of main lobe at  $-6\text{dB}$  level have been obtained during the experiments. These data are presented in the table 2. From this table one can see that window based on function  $Fup_4(x)D_3(x)$  offers better resolution and does not increase the main lobe width as well as the windows  $Fup_4(x)D_{3,5}(x)$  and  $Fup_6^2(x)G_2^2(x)$  among the family of novel windows.

## 9. Conclusions

This paper presents a comparative performance of different window functions applied during the pulse compression in radar. The best results have been obtained using atomic function window  $up(x)$ , which characterizes by better performance, such as the better side-lobes level performance in presence of noise, and small degradation in range resolution. With regard to classical windows the best windows are Hamming and Kaiser-Bessel, both with similar parameters.

The implementation of the compression-windowing techniques on FPGA in real time mode let us know that significant decreasing of the lateral lobes by some classical and AF windows is possible. The performances of atomic functions used in here have proven possible applications of novel windows in the processing of radar data.

Future research work requires additional investigation in the performance of parameters during the windowing procedure, and also we recommend testing novel windows in frequency domain using FPGA.

## Acknowledgement

The authors thank the PROMEP, IPN and CONACYT for its support.

## 10. References

- [1] Charles E. C. and Marvin B., Radar Signals: An introduction to theory and application, Artech House, 1993.
- [2] Merrill I. Skolnik, Radar handbook, McGraw Hill, 1990.
- [3] Fred E. Natashon and J. Patrick Reilly, Radar design principles, Scitech Publishing, INC, 1999.
- [4] Y. V. Shkvarko, Unifying regularization and Bayesian estimation methods for enhanced imaging with remotely sensed data, parts I, II. IEEE Trans. on geoscience and remote sensing, 42 (5): pp. 923-940, 2004.

- [5] E. Escamilla-Hernandez, V.F. Kravchenko, V.I. Ponomaryov, and D.V. Smirnov, Radar Processing on Basis of Kravchenko-Rvachev's Functions for Resolving of Numerical Targets, Telecommunications and Radio Engineering, Vol 65, pp. 209-224 2006
- [6] A. H. Nuttall, Some windows with very good sidelobe behavior, IEEE Trans. on acoustic, speech and signal processing, ASSP-29(1), pp. 84-91, 1981.
- [7] F. J. Harris, On the use of window for harmonic analysis with the DFT, IEEE Proc., 66(1), pp. 51-83, 1978
- [8] C. Max Maxfield, The design warrior's guide to FPGA's, Newnes, 2004
- [9] V. F. Kravchenko, New synthesized windows, Doklady Physics, 47(1), pp 51-60, 2002.
- [10] E. Escamilla, A. Ikuo, H. Endo, V. Ponomaryov, Performance of weighting function to reduce sidelobes in pulse compression radar, The 10th UEC international mini-conference for ES., UEC, 2003, Tokyo, Japan, pp. 21-26.
- [11] Humberto César C. Fernandes, Victor F. Kravchenko, "Applications of the atomic functions in the antennas theory", Journal of Microwaves and Optoelectronics, Vol. 2, No. 2, pp. 10-19, December 2000.
- [12] V. F. Kravchenko, M. A. Basarab, V. I. Pustovoi, H. Perez Meana, "New Constructions of Weight Windows Based on Atomic Functions in Problems of Speech-Signal Processing", Doklady Physics, 46(3), pp. 166-172, 2001.
- [13] V. F. Kravchenko, M. A. Basarab, "A New Method of Multidimensional-Signal Processing with the Use of R Functions and Atomic Functions", Doklady Physics, 47(3), 2002, pp. 195-200.
- [14] V. Ponomaryov, E. Escamilla, "Real-Time Windowing in Imaging Radar Using FPGA Technique", Real-time imagine IX, San Jose, California, USA, 2005, Proc. SPIE, V. 5671, pp. 152-161.
- [15] [http://www.xilinx.com/products/design\\_resources/dsp\\_central/grouping/index.htm](http://www.xilinx.com/products/design_resources/dsp_central/grouping/index.htm).
- [16] J. Volder, The CORDIC Computing Technique, IRE Trans. Computers, v. EC-8, 1959, pp.330-334.
- [17] Hai Xiang Lin, Henk J. Sips, On-line CORDIC algorithms, IEEE Trans. on Computer, 39(8), August 1990. pp.1038-1052.

# Instituto Politécnico Nacional

Escuela Superior de Ingeniería Mecánica y Eléctrica  
Sección de Estudios de Posgrado e Investigación

5° Congreso Internacional de Ingeniería  
Electromecánica y de Sistemas  
CIIES 2008

del 10 al 14 de noviembre

contacto: [isosa@ipn.mx](mailto:isosa@ipn.mx), [mgalaz@ipn.mx](mailto:mgalaz@ipn.mx).

[www.ciies.ipn.mx](http://www.ciies.ipn.mx)